

AIR SHAMMEE

TOUCHLESS SPOTFREE DRYING SYSTEM

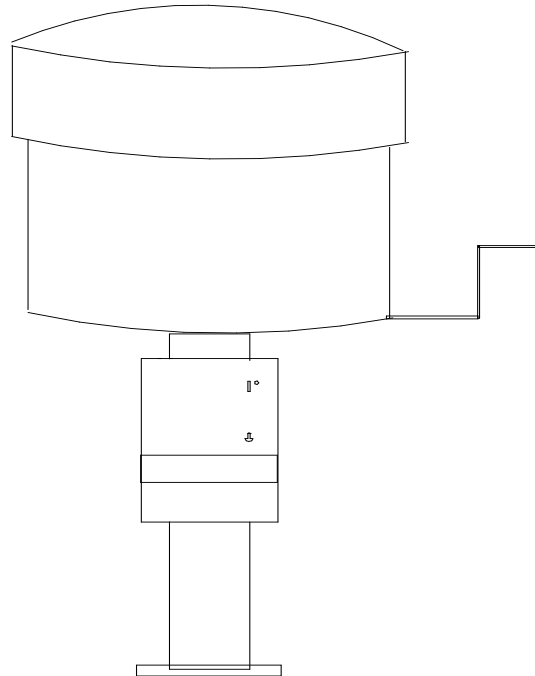

INSTALLATION MANUAL

(FOR MODEL ASHSA SERIES I WALL/PEDISTAL MOUNT DRYER UNIT)

DISKIN SYSTEMS INC.
30 Victor Parkway
Crystal Lake, IL 60014
Phone: 815-276-7288
Fax: 847-608-8133

SAFETY FIRST: ALWAYS OBSERVE ALL SAFETY GUIDELINES PROVIDED BY MANUFACTURERS WHEN INSTALLING OR SERVICING AIR SHAMMEE UNIT.

Installation Manual

WARNING: READ ENTIRE INSTALLATION MANUAL BEFORE ATTEMPTING TO INSTALL UNIT. FAILURE TO READ AND UNDERSTAND INSTALLATION PROCESS CAN LEAD TO SERIOUS INJURY OR DAMAGE TO AIR SHAMMEE UNIT.

AIR SHAMMEE DRYER SYSTEM INSTALLATION

WARNING: NEVER ATTEMPT INSTALLATION OR MAINTENANCE OF AIR SHAMMEE/VACUUM UNIT WITHOUT DICONNECTING ELECTRICAL SERVICE. FAILURE TO DISCONNECT ELECTRICAL SERVICE CAN RESULT IN PROPERTY DAMAGE, SERIOUS INJURY OR DEATH BY ELECTROCUTION.

PRIOR TO INSTALLATION:

BEFORE ATTEMPTING AIR SHAMMEE INSTALLATION PLEASE CHECK THE FOLLOWING REQUIREMENTS:

ELECTRICAL REQUIREMENTS

1. 110V SINGLE PHASE SERVICE TO AIR SHAMMEE.
2. 3 20 AMP CIRCUIT BREAKERS AT ELECTRICAL DISTRIBUTION BOX. (If 3 positions are not open in the panel use a 30 amp and 20 amp breaker)
3. 3 DROP LINE'S RATED TO CARRY 20 AMP 110V SERVICE

SAFETY FIRST: ALWAYS OBSERVE ALL SAFETY GUIDELINES PROVIDED BY MANUFACTURERS WHEN INSTALLING OR SERVICING AIR SHAMMEE UNIT.

MOUNTING OF UNIT TO WALL/VAC ISLAND

1. LOCATE THE WALL MOUNTING BRACKET OR PEDISTAL SHIPPED WITH THE AIR SHAMMEE UNIT.

2. IN ORDER TO MOUNT THIS, HOLES MUST BE DRILLED IN THE SURFACE ON WHICH THE AIR SHAMMEE UNIT WILL BE LOCATED.

3. CAREFULLY PLACE THE MOUNTING BRACKET/PEDISTAL AT THE EXACT LOCATE YOU WISH TO PLACE THE UNIT, AND MARK THE POSITION OF THE BOLT HOLES.

4. DRILL HOLES USING THE APPROPRIATE TOOLS TO ACCOMMODATE THE LAG BOLT WHICH WILL HOLD THE UNIT TO THE MOUNTING SURFACE. BE SURE NOT TO DRILL THE LAG HOLE TOO WIDE OR THE LAG BOLT WILL NOT THREAD INTO THE HOLE PROPERLY.

NOTE: LAG BOLTS NOT PROVIDED.

5. USING FOUR (4) STANDARD LAG BOLTS AT LEAST 4" IN LENGTH (6" IS RECOMMENDED) SCREW THE LAG BOLTS INTO THE MOUNTING HOLES.

BE SURE TO CHECK FOR SECURE ATTACHMENT OF THE PEDISTAL/WALL BRACKET!!!

SAFETY FIRST: ALWAYS OBSERVE ALL SAFETY GUIDELINES PROVIDED BY MANUFACTURERS WHEN INSTALLING OR SERVICING AIR SHAMMEE UNIT.

NOTE: ALL MOUNTING BOLTS USE NYLOC TYPE NUTS WHICH ARE A BIT HARDER TO INSTALL, BUT THEY ARE TAMPERPROOF

6. ONCE THE UPPER BOLTS ARE IN PLACE THE LOWER BOLTS ARE INSERTED IN THE APPROPRIATE HOLES AND TIGHTENED.

7. CHECK THE ENTIRE ASSEMBLY FOR SECURE ATTACHMENT TO THE WALL.

8. INSERT THE HOSE ASSEMBLY INTO THE EXHAUST HOLE LOCATED ON THE RIGHT SIDE OF THE UNIT. DUE TO VARIATIONS THAT OCCUR DURING PRODUCTION THE OUTLET MAINFOLD MIGHT NOT LINE UP EXACTLY WITH THE HOSE HOLE. IF THIS HAPPENS GENTLY FLEX THE MANIFOLD ASSEMBLY UNTIL THE HOSE SLIDES ON TO IT.

9. SECURE THE HOSE USING THE STAINLESS STEEL BAND CLAMP PROVIDED.

SAFETY FIRST: ALWAYS OBSERVE ALL SAFETY GUIDELINES PROVIDED BY MANUFACTURERS WHEN INSTALLING OR SERVICING AIR SHAMMEE UNIT.

AIR SHAMMEE UNIT ELECTRICAL INSTALLATION

WARNING: NEVER ATTEMPT INSTALLATION OR MAINTENANCE OF AIR SHAMMEE/VACUUM UNIT WITHOUT DICONNECTING ELECTRICAL SERVICE. FAILURE TO DISCONNECT ELECTRICAL SERVICE CAN RESULT IN PROPERTY DAMAGE, SERIOUS INJURY OR DEATH BY ELECTROCUTION

1. MAKE SURE ALL ELECTRICAL POWER IS DISCONNECTED BEFORE WIRING!!!
2. CAREFULLY RUN THE SERVICE WIRES IN THROUGH THE COINBOX HOLE AND ATTACH THE CONDUIT.
3. INSIDE THE UNIT ATTACH THE COMMON (WHITE), HOT (BLACK) AND THE GROUND (GREEN) TO THE SERVICE WIRES. BLACK TO BLACK, WHITE TO WHITE, GREEN TO GREEN USING WIRE NUTS.

IMPORTANT: ALWAYS OBSERVE ALL NATIONAL AND LOCAL ELECTRICAL CODES WHEN INSTALLING THIS UNIT.

4. ONCE THE WIRES ARE ATTACHED PROPERLY SECURE THE WIRES WITHIN THE UNIT USING TAPE OR WIRE TIES SO THE WIRES ARE NOT LOOSE IN THE UNIT.
5. NOW THE UNIT IS READY TO BE TURNED ON. THOROUGHLY INSPECT THE INSTALLATION FOR ANY LOOSE CONNECTIONS, AND RECONNECT POWER TO THE UNIT.

SAFETY FIRST: ALWAYS OBSERVE ALL SAFETY GUIDELINES PROVIDED BY MANUFACTURERS WHEN INSTALLING OR SERVICING AIR SHAMMEE UNIT.

6. INSERT COINS INTO THE COIN MECHANISM AND CHECK FOR PROPER OPERATION. IF NECESSARY ADJUST THE TIMER SETTINGS UNTIL TIME AND COIN COUNT ARE CORRECT.

7. RUN UNIT FOR 2 OR 3 CYCLES AND CHECK FOR AIR LEAKS, EXTREME VIBRATION, EXCESSIVE NOISE, OR ANYTHING UNUSUAL. NO BREAK IN PERIOD IS NECESSARY.

SAFETY FIRST: ALWAYS OBSERVE ALL SAFETY GUIDELINES PROVIDED BY MANUFACTURERS WHEN INSTALLING OR SERVICING AIR SHAMMEE UNIT.

Air Shamree Stand Alone With IMONEX Coin Mech

110 volt Touchless Spotfree Drying System

**USING 1 40 AMP BREAKER
OR USE 3 15 AMP BREAKERS**

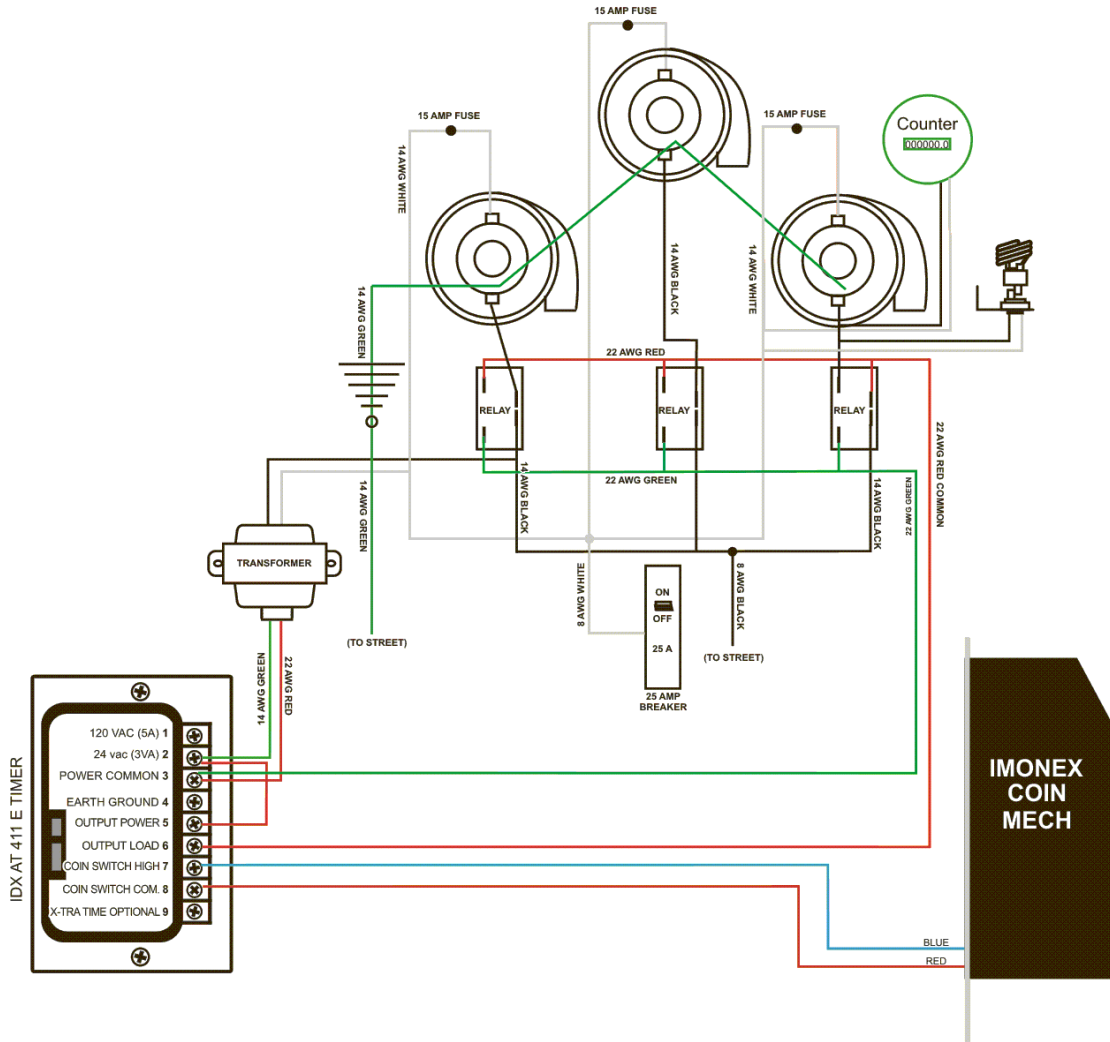

SAFETY FIRST: ALWAYS OBSERVE ALL SAFETY GUIDELINES PROVIDED BY MANUFACTURERS WHEN INSTALLING OR SERVICING AIR SHAMREE UNIT.