

# EXTREME AIR

## TIRE INFLATOR

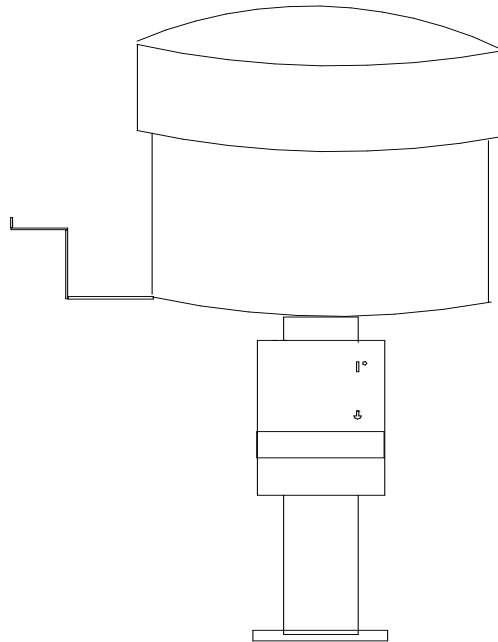

## INSTALLATION MANUAL

(FOR MODEL DSCOMP EXTREME TIRE INFLATOR)

DISKIN SYSTEMS INC.  
30 Victor Parkway  
Crystal Lake, IL 60014  
Phone: 815-276-7288  
Fax: 847-608-8133

**SAFETY FIRST: ALWAYS OBSERVE ALL SAFETY GUIDELINES PROVIDED BY MANUFACTURERS WHEN INSTALLING OR SERVICING AIR SHAMMEE UNIT.**

---

***Installation Manual***

**WARNING: READ ENTIRE INSTALLATION MANUAL BEFORE ATTEMPTING TO INSTALL UNIT. FAILURE TO READ AND UNDERSTAND INSTALLATION PROCESS CAN LEAD TO SERIOUS INJURY OR DAMAGE TO AIR SHAMMEE UNIT.**

\*\*\*\*\*

**EXTREME AIR SYSTEM INSTALLATION**

**WARNING: NEVER ATTEMPT INSTALLATION OR MAINTENANCE OF EXTREME AIR/TIRE INFLATOR WITHOUT DICONNECTING ELECTRICAL SERVICE. FAILURE TO DISCONNECT ELECTRICAL SERVICE CAN RESULT IN PROPERTY DAMAGE, SERIOUS INJURY OR DEATH BY ELECTROCUTION.**

\*\*\*\*\*

**PRIOR TO INSTALLATION:**

BEFORE ATTEMPTING EXTREME AIR INSTALLATION PLEASE CHECK THE FOLLOWING REQUIREMENTS:

**ELECTRICAL REQUIREMENTS**

1. 20 AMP 110V SINGLE PHASE SERVICE TO VACUUM UNIT.
2. 20 AMP CIRCUIT BREAKER AT ELECTRICAL DISTRIBUTION BOX.
3. DROP LINE RATED TO CARRY 20 AMP 110V SERVICE.

**MOUNTING OF UNIT TO WALL/VAC ISLAND**

**SAFETY FIRST: ALWAYS OBSERVE ALL SAFETY GUIDELINES PROVIDED BY MANUFACTURERS WHEN INSTALLING OR SERVICING AIR SHAMMEE UNIT.**

1. LOCATE THE WALL MOUNTING BRACKET OR PEDISTAL SHIPPED WITH THE EXTREME AIR UNIT.

2. IN ORDER TO MOUNT THIS, HOLES MUST BE DRILLED IN THE SURFACE ON WHICH THE EXTREME AIR UNIT WILL BE LOCATED.

3. CAREFULLY PLACE THE MOUNTING BRACKET/PEDISTAL AT THE EXACT LOCATE YOU WISH TO PLACE THE UNIT, AND MARK THE POSITION OF THE BOLT HOLES.

4. DRILL HOLES USING THE APPROPRIATE TOOLS TO ACCOMMODATE THE LAG BOLT WHICH WILL HOLD THE UNIT TO THE MOUNTING SURFACE. BE SURE NOT TO DRILL THE LAG HOLE TOO WIDE OR THE LAG BOLT WILL NOT THREAD INTO THE HOLE PROPERLY.

NOTE: LAG BOLTS NOT PROVIDED.

5. USING FOUR (4) STANDARD LAG BOLTS AT LEAST 4" IN LENGTH (6" IS RECOMMENDED) SCREW THE LAG BOLTS INTO THE MOUNTING HOLES.

**BE SURE TO CHECK FOR SECURE ATTACHMENT OF THE PEDISTAL/WALL BRACKET!!!**

**NOTE:** ALL MOUNTING BOLTS USE NYLOC TYPE NUTS WHICH ARE A BIT HARDER TO INSTALL, BUT THEY ARE TAMPERPROOF WITH THE NUT ON THE INSIDE. IF THE BOLT IS TURNED FROM THE OUTSIDE THE NUT WILL NOT LOOSEN OR UNTHREAD.

6. ONCE THE UPPER BOLTS ARE IN PLACE THE LOWER BOLTS ARE INSERTED IN THE APPROPRIATE HOLES AND TIGHTENED.

7. CHECK THE ENTIRE ASSEMBLY FOR SECURE ATTACHMENT TO THE WALL/PEDISTAL.

**SAFETY FIRST:** ALWAYS OBSERVE ALL SAFETY GUIDELINES PROVIDED BY MANUFACTURERS WHEN INSTALLING OR SERVICING AIR SHAMMEE UNIT.

---

**EXTREME AIR UNIT ELECTRICAL INSTALLATION**

\*\*\*\*\*

**WARNING: NEVER ATTEMPT INSTALLATION OR MAINTENANCE OF AIR SHAMMEE/VACUUM UNIT WITHOUT DICONNECTING ELECTRICAL SERVICE. FAILURE TO DISCONNECT ELECTRICAL SERVICE CAN RESULT IN PROPERTY DAMAGE, SERIOUS INJURY OR DEATH BY ELECTROCUTION**

\*\*\*\*\*

1. MAKE SURE ALL ELECTRICAL POWER IS DISCONNECTED BEFORE WIRING!!!
2. CAREFULLY RUN THE SERVICE WIRES IN THROUGH THE COINBOX HOLE AND ATTACH THE CONDUIT.
3. INSIDE THE UNIT ATTACH THE COMMON (WHITE), HOT (BLACK) AND THE GROUND (GREEN) TO THE SERVICE WIRES. BLACK TO BLACK, WHITE TO WHITE, GREEN TO GREEN USING WIRE NUTS.

**IMPORTANT: ALWAYS OBSERVE ALL NATIONAL AND LOCAL ELECTRICAL CODES WHEN INSTALLING THIS UNIT.**

4. ONCE THE WIRES ARE ATTACHED PROPERLY SECURE THE WIRES WITHIN THE UNIT USING TAPE OR WIRE TIES SO THE WIRES ARE NOT LOOSE IN THE UNIT.
5. NOW THE UNIT IS READY TO BE TURNED ON. THOROUGHLY INSPECT THE INSTALLATION FOR ANY LOOSE CONNECTIONS, AND RECONNECT POWER TO THE UNIT.

**SAFETY FIRST: ALWAYS OBSERVE ALL SAFETY GUIDELINES PROVIDED BY MANUFACTURERS WHEN INSTALLING OR SERVICING AIR SHAMMEE UNIT.**

6. INSERT COINS INTO THE COIN MECHANISM AND CHECK FOR PROPER OPERATION. IF NECESSARY ADJUST THE TIMER SETTINGS UNTIL TIME AND COIN COUNT ARE CORRECT.

7. RUN UNIT FOR 2 OR 3 CYCLES AND CHECK FOR AIR LEAKS, EXTREME VIBRATION, EXCESSIVE NOISE, OR ANYTHING UNUSUAL. NO BREAK IN PERIOD IS NECESSARY.

**SAFETY FIRST:** ALWAYS OBSERVE ALL SAFETY GUIDELINES PROVIDED BY MANUFACTURERS WHEN INSTALLING OR SERVICING AIR SHAMMEE UNIT.

## DSCOMP ExTreme AIR Compressor Wiring Schematic

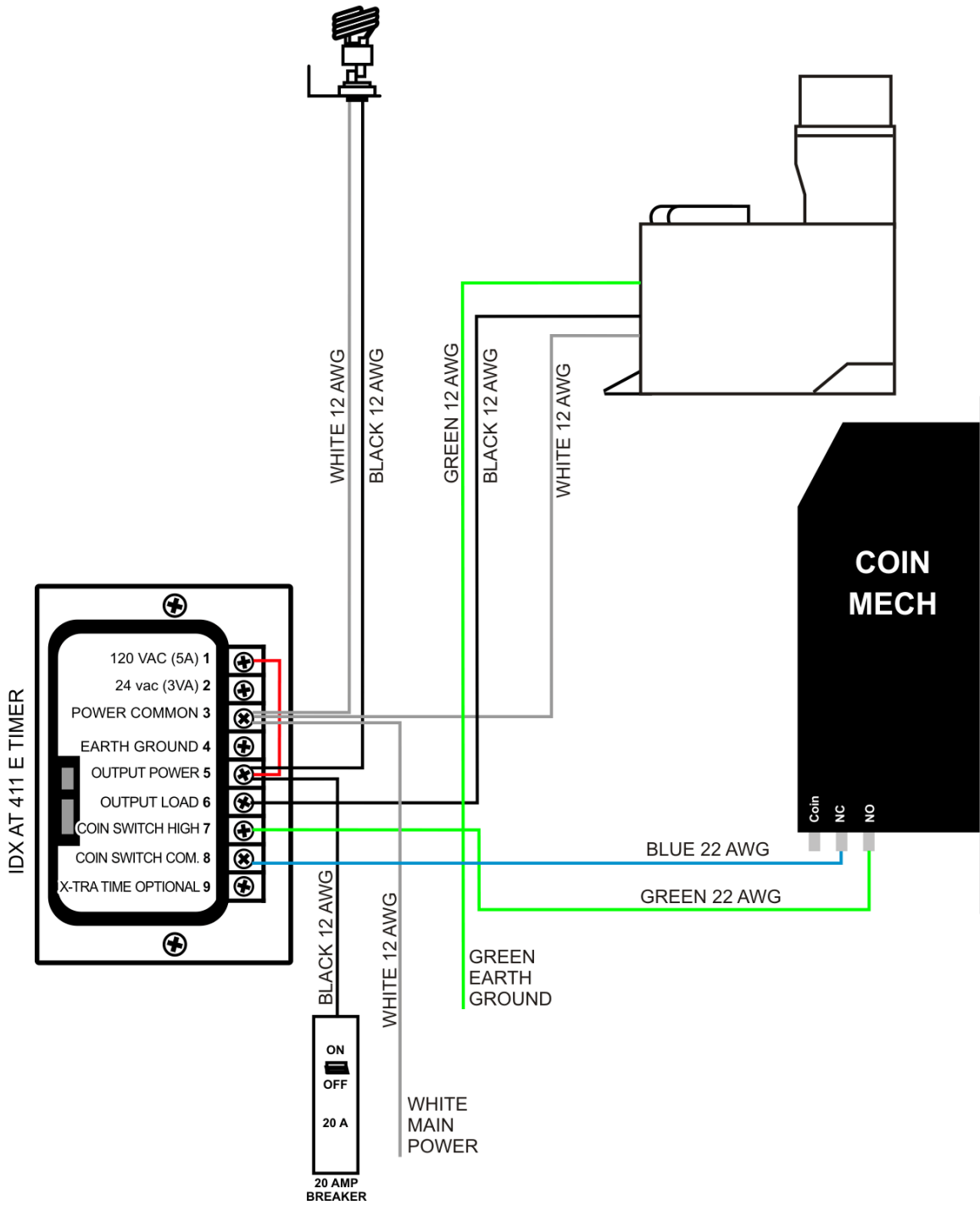

**SAFETY FIRST:** ALWAYS OBSERVE ALL SAFETY GUIDELINES PROVIDED BY MANUFACTURERS WHEN INSTALLING OR SERVICING AIR SHAMMEE UNIT.