

Coinbox Air Compressor

Controlled 110 volt air dispensing coinbox

Installation Manual

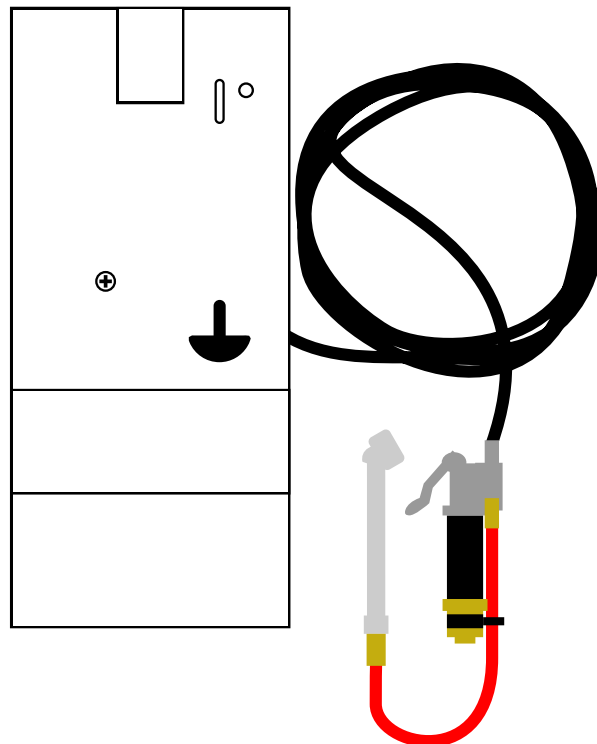

(Model CBCOMP)

30 Victor Parkway
Crystal Lake, IL 60014
Phone: 815-276-7288
Fax: 847-608-8133



SAFETY FIRST

Always Observe all safety guidelines provided by manufacturer when installing or servicing coinbox compressor.

Coinbox Air Compressor

Controlled 110 volt air dispensing coinbox

WARNING: read entire installation manual before attempting to install unit. Failure to read and understand installation process can lead to damage to coinbox unit and/or serious injury.

PRIOR TO INSTALLATION:

Before attempting coinbox installation please check the following requirements:

REQUIREMENTS

1. 110v single phase service to coinbox.
2. 1 15 amp circuit breaker at electrical distribution box.
3. 1 drop line rated to carry 15 amp 110 volt service.
4. 4 bolt to mount the coinbox and 2 bolts to mount the hose hook.



SAFETY FIRST

Always Observe all safety guidelines provided by manufacturer when installing or servicing coinbox compressor.

Coinbox Air Compressor

Controlled 110 volt air dispensing coinbox

INSTALLATION OF THE COINBOX:

1. Disconnect all electrical service to the bay. (You will be drilling into the wall and must avoid drilling through any conduit.)
2. Remove the coin bin and face plate.
3. Hold the coinbox to the wall or mounting surface, and mark mounting holes and conduit hole.
4. Using proper fasteners, bolt the coinbox to the mounting surface.
5. Screw your supply hose into the solenoid using tethlon tape.
6. Mark and drill holes for the hose hook.



SAFETY FIRST

Always Observe all safety guidelines provided by manufacturer when installing or servicing coinbox compressor.

Coinbox Air Compressor

Controlled 110 volt air dispensing coinbox

COINBOX ELECTRICAL INSTALLATION

IMPORTANT: always observe all national and local electrical codes when installing this unit.

1. Connect the black, white, and green wires to the wires your electrician has supplied.
2. Check all wires for loose connections.
3. The coinbox ins now wired for service, turn on the 15 amp circuit breaker and, insert coins to start.

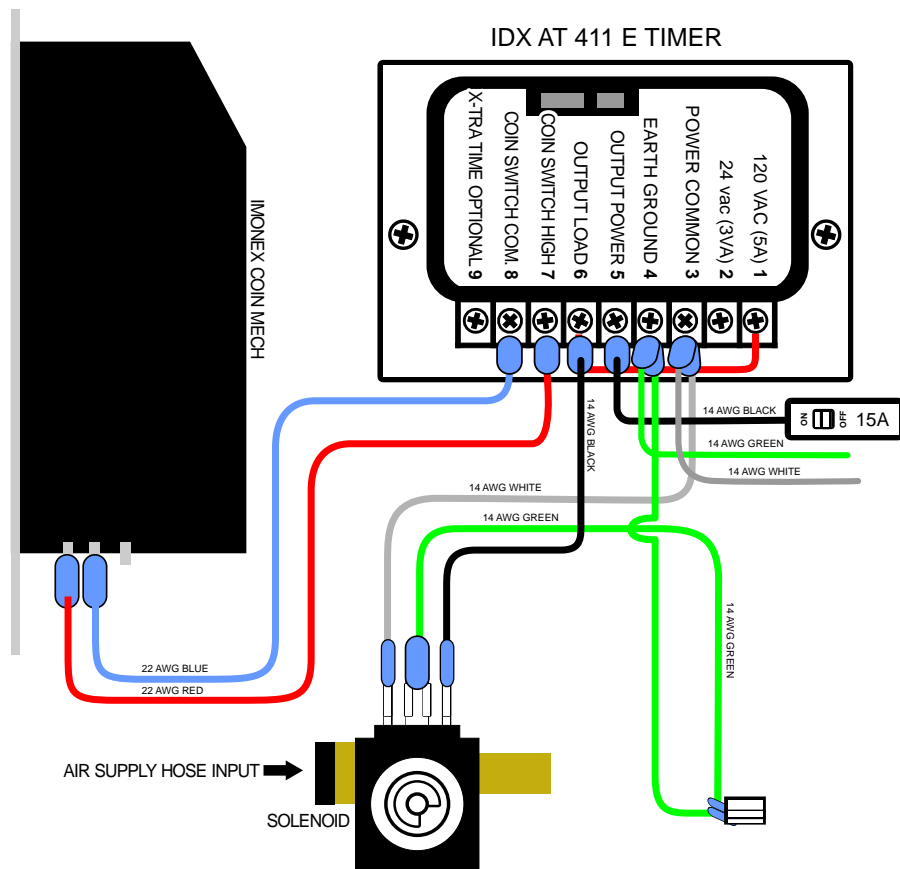

SAFETY FIRST

Always Observe all safety guidelines provided by manufacturer when installing or servicing coinbox compressor.