

EXTREME AIR/AIR SHAMMEE COMBO

TIRE INFLATOR SPOTFREE TOUCHLESS DRYING SYSTEM

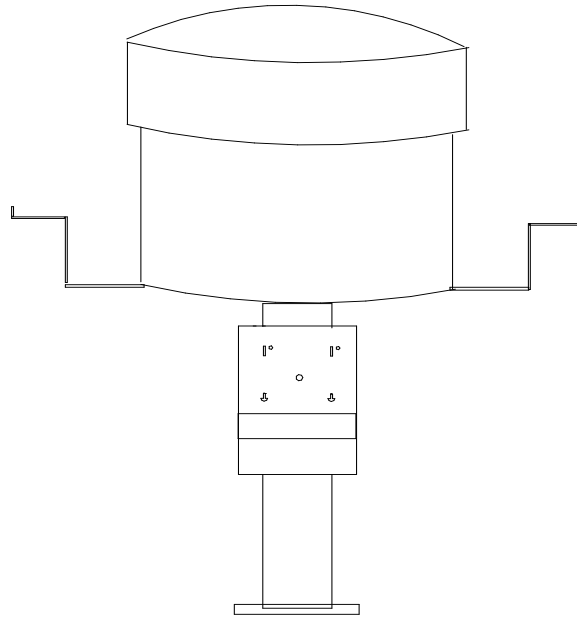

INSTALLATION MANUAL

(FOR MODEL EXASH TIRE INFLATOR/DRYING UNIT)

DISKIN SYSTEMS INC.
30 Victor Parkway
Crystal Lake, IL 60014
Phone: 815-276-7288
Fax: 847-608-8133

SAFETY FIRST: ALWAYS OBSERVE ALL SAFETY GUIDELINES PROVIDED BY MANUFACTURERS WHEN INSTALLING OR SERVICING AIR SHAMMEE UNIT.

Installation Manual

WARNING: READ ENTIRE INSTALLATION MANUAL BEFORE ATTEMPTING TO INSTALL UNIT. FAILURE TO READ AND UNDERSTAND INSTALLATION PROCESS CAN LEAD TO SERIOUS INJURY OR DAMAGE TO AIR SHAMMEE UNIT.

**AIR SHAMMEE DRYER SYSTEM/TIRE INFLATOR
INSTALLATION**

WARNING: NEVER ATTEMPT INSTALLATION OR MAINTENANCE OF AIR SHAMMEE/INFLATOR UNIT WITHOUT DICONNECTING ELECTRICAL SERVICE. FAILURE TO DISCONNECT ELECTRICAL SERVICE CAN RESULT IN PROPERTY DAMAGE, SERIOUS INJURY OR DEATH BY ELECTROCUTION.

PRIOR TO INSTALLATION:

BEFORE ATTEMPTING AIR SHAMMEE/INFLATOR INSTALLATION PLEASE CHECK THE FOLLOWING REQUIREMENTS:

ELECTRICAL REQUIREMENTS

1. 30 AMP 240V
2. DROP LINE RATED TO CARRY 30 AMP SINGLE PHASE SERVICE TO EXASH.
3. 30 AMP 240V SERVICE CIRCUIT BREAKER AT ELECTRICAL DISTRIBUTION.

SAFETY FIRST: ALWAYS OBSERVE ALL SAFETY GUIDELINES PROVIDED BY MANUFACTURERS WHEN INSTALLING OR SERVICING AIR SHAMMEE UNIT.

MOUNTING OF UNIT TO WALL/VAC ISLAND

1. LOCATE THE PEDISTAL SHIPPED WITH THE AIR SHAMMEE UNIT.
2. IN ORDER TO MOUNT THIS, HOLES MUST BE DRILLED IN THE SURFACE ON WHICH THE AIR SHAMMEE UNIT WILL BE LOCATED.
3. CAREFULLY PLACE THE MOUNTING BRACKET/PEDISTAL AT THE EXACT LOCATE YOU WISH TO PLACE THE UNIT, AND MARK THE POSITION OF THE BOLT HOLES.
4. DRILL HOLES USING THE APPROPRIATE TOOLS TO ACCOMMODATE THE 3/8 INCH LAG BOLT WHICH WILL HOLD THE UNIT TO THE MOUNTING SURFACE. BE SURE NOT TO DRILL THE LAG HOLE TOO WIDE OR THE LAG BOLT WILL NOT EXPAND INTO THE HOLE PROPERLY.
NOTE: LAG BOLTS NOT PROVIDED.
5. USING FOUR (4) STANDARD LAG BOLTS AT LEAST 4" IN LENGTH (6" IS RECOMMENDED) SCREW THE LAG BOLTS INTO THE MOUNTING HOLES.

BE SURE TO CHECK FOR SECURE ATTACHMENT OF THE PEDISTAL/WALL BRACKET!!!

NOTE: ALL MOUNTING BOLTS USE NYLOC TYPE NUTS WHICH ARE A BIT HARDER TO INSTALL, BUT THEY ARE TAMPERPROOF WITH THE NUT ON THE INSIDE. IF THE BOLT IS TURNED FROM THE OUTSIDE THE NUT WILL NOT LOOSEN OR UNTHREAD.

SAFETY FIRST: ALWAYS OBSERVE ALL SAFETY GUIDELINES PROVIDED BY MANUFACTURERS WHEN INSTALLING OR SERVICING AIR SHAMMEE UNIT.

7 CHECK THE ENTIRE ASSEMBLY FOR SECURE ATTACHMENT TO THE WALL/PEDISTAL.

8. INSTALL HOSE ASSEMBLY BY LOOSENING THE WING NUTS THAT SECURE THE MOTOR PLATE TO THE AIR SHAMMEE HOUSING. LIFT UP ON THE MOTOR PLATE AND SLIDE HOSE ONTO AIR CHANNELING FUNNEL. AS YOU LOWER THE MOTOR PLATE COMPRESS THE HOSE INTO THE U SHAPED CONTOUR IN THE AIR SHAMMEE HOUSING.

9. SECURE THE HOSE USING THE STAINLESS STEEL BAND CLAMP PROVIDED.

|

SAFETY FIRST: ALWAYS OBSERVE ALL SAFETY GUIDELINES PROVIDED BY MANUFACTURERS WHEN INSTALLING OR SERVICING AIR SHAMMEE UNIT.

AIR SHAMMEE UNIT ELECTRICAL INSTALLATION

WARNING: NEVER ATTEMPT INSTALLATION OR MAINTENANCE OF AIR SHAMMEE/VACUUM UNIT WITHOUT DICONNECTING ELECTRICAL SERVICE. FAILURE TO DISCONNECT ELECTRICAL SERVICE CAN RESULT IN PROPERTY DAMAGE, SERIOUS INJURY OR DEATH BY ELECTROCUTION

1. MAKE SURE ALL ELECTRICAL POWER IS DISCONNECTED BEFORE WIRING!!!
2. CAREFULLY RUN THE SERVICE WIRES IN THROUGH THE COINBOX HOLE AND ATTACH THE CONDUIT.
3. INSIDE THE UNIT ATTACH THE COMMON (BLUE), HOT (BROWN) AND THE GROUND (GREEN) TO THE SERVICE WIRES. BROWN TO BROWN, BLUE TO BLUE, GREEN TO GREEN USING WIRE NUTS.

IMPORTANT: ALWAYS OBSERVE ALL NATIONAL AND LOCAL ELECTRICAL CODES WHEN INSTALLING THIS UNIT.

4. ONCE THE WIRES ARE ATTACHED PROPERLY SECURE THE WIRES WITHIN THE UNIT USING TAPE OR WIRE TIES SO THE WIRES ARE NOT LOOSE IN THE UNIT.
5. NOW THE UNIT IS READY TO BE TURNED ON. THOROUGHLY INSPECT THE INSTALLATION FOR ANY LOOSE CONNECTIONS, AND RECONNECT POWER TO THE UNIT.
6. INSERT COINS INTO THE COIN MECHANISM AND CHECK FOR PROPER OPERATION. IF NECESSARY ADJUST THE TIMER SETTINGS UNTIL TIME AND COIN COUNT ARE CORRECT.

SAFETY FIRST: ALWAYS OBSERVE ALL SAFETY GUIDELINES PROVIDED BY MANUFACTURERS WHEN INSTALLING OR SERVICING AIR SHAMMEE UNIT.

EXASH 240 VOLT WIRING SCHEMATIC

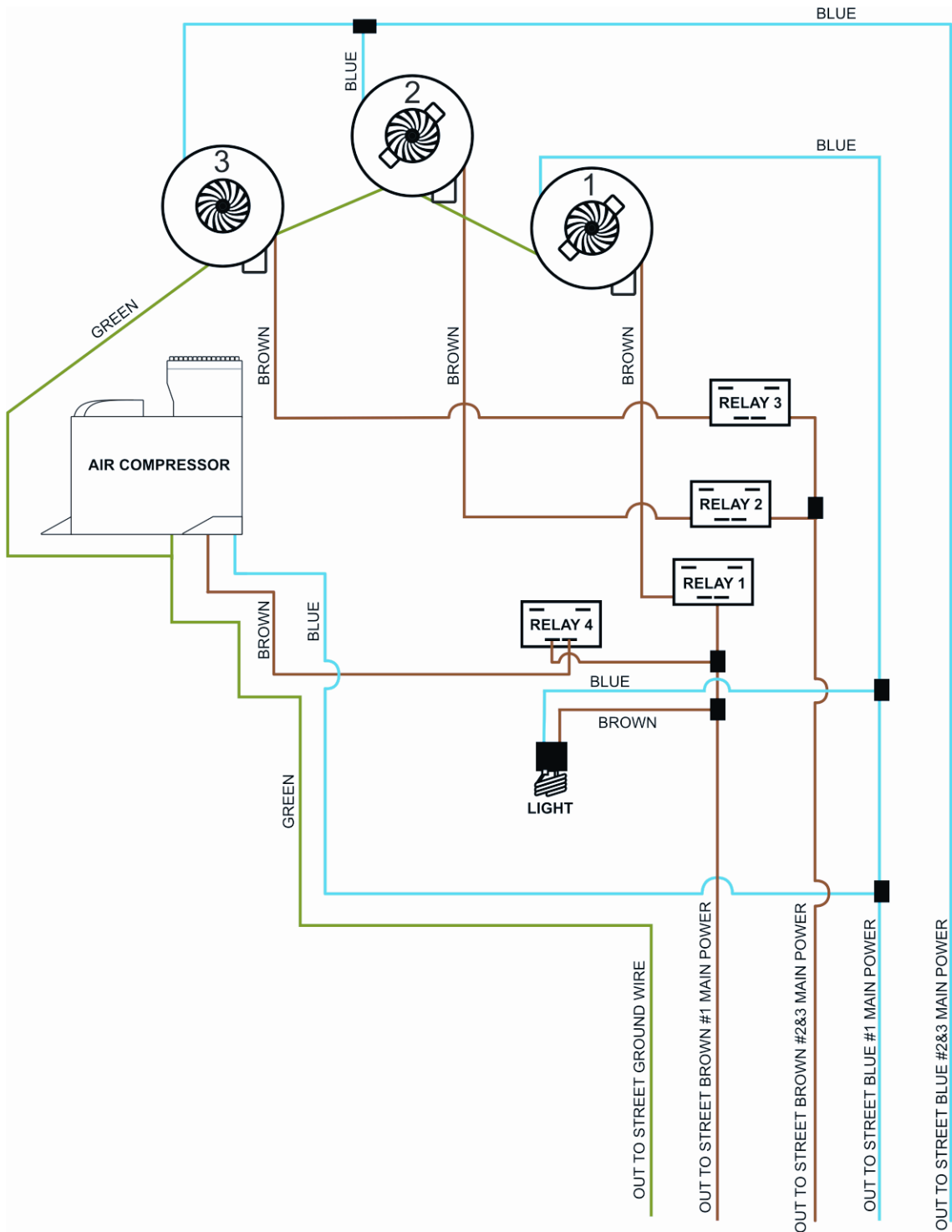

SAFETY FIRST: ALWAYS OBSERVE ALL SAFETY GUIDELINES PROVIDED BY MANUFACTURERS WHEN INSTALLING OR SERVICING AIR SHAMMEE UNIT.

EXASH LOW VOLTAGE 24 VOLT WIRING SCHEMATIC

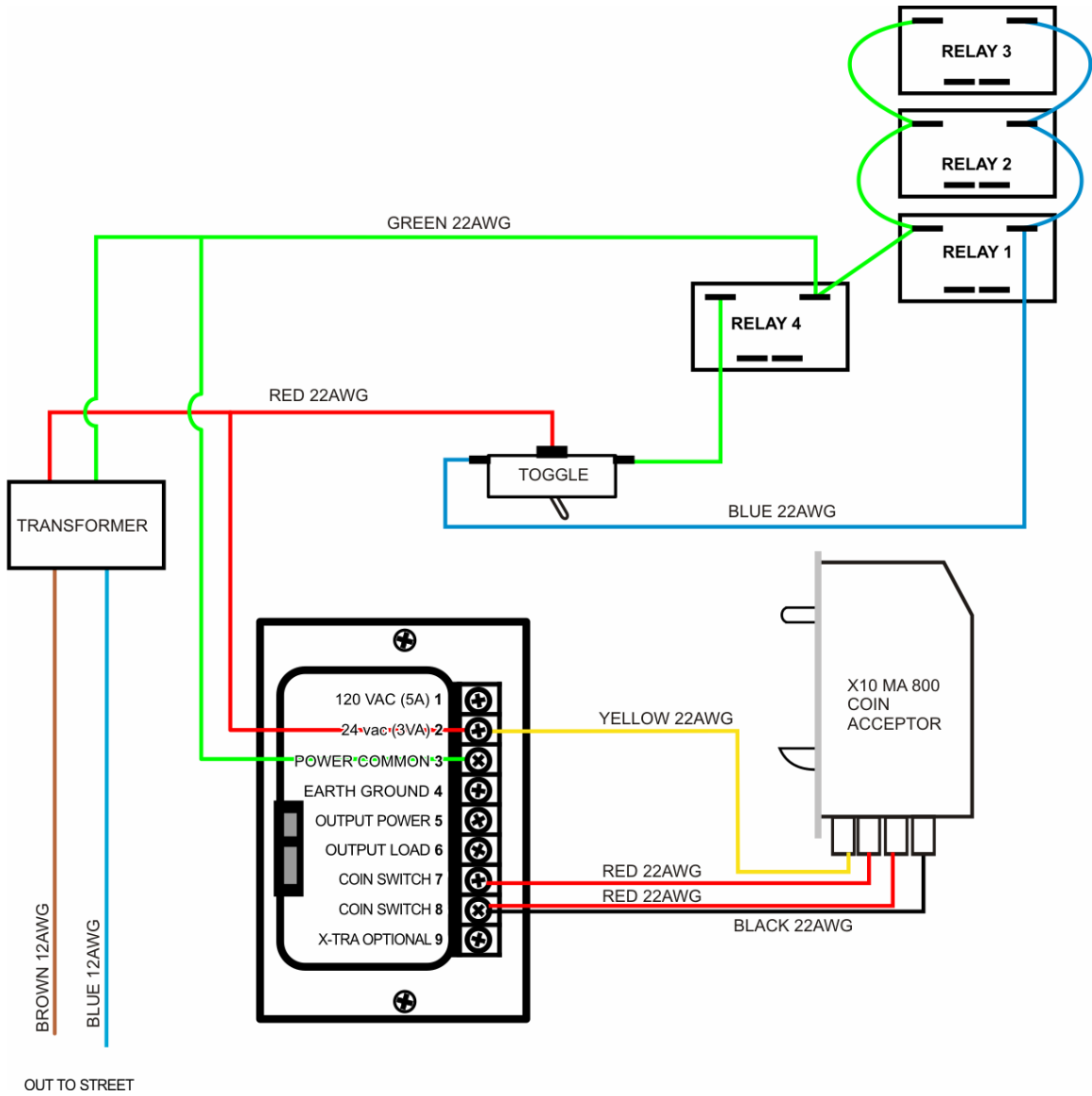

SAFETY FIRST: ALWAYS OBSERVE ALL SAFETY GUIDELINES PROVIDED BY MANUFACTURERS WHEN INSTALLING OR SERVICING AIR SHAMMEE UNIT.

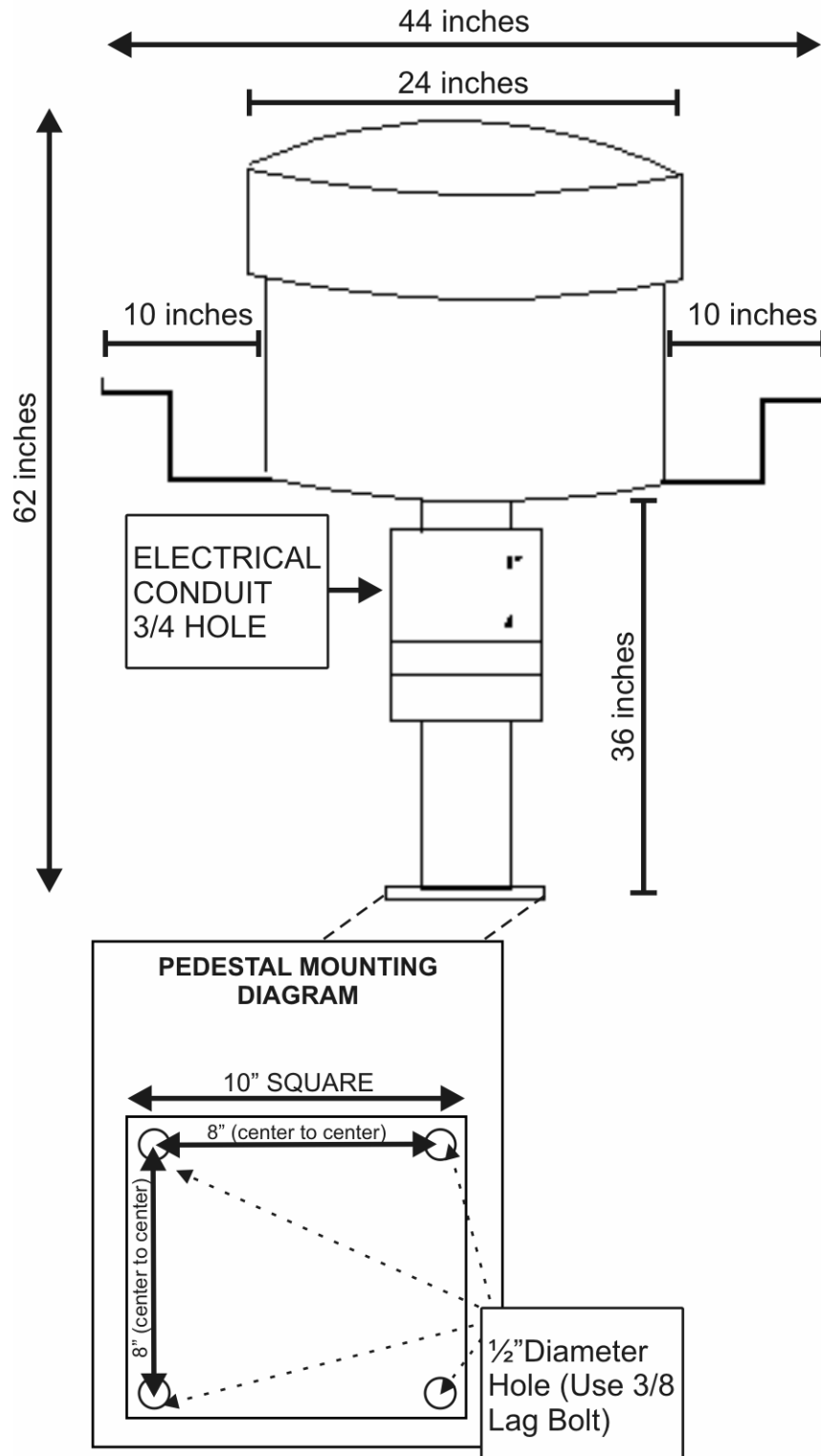

SAFETY FIRST: ALWAYS OBSERVE ALL SAFETY GUIDELINES PROVIDED BY MANUFACTURERS WHEN INSTALLING OR SERVICING AIR SHAMMEE UNIT.